

Specification

Model Name		OLM-4610	OLM-4650
Power Supply		AC100V ~ 240V (50/60Hz)	
Power Consumption	Max	200W	285W
	Typical	130W	190
	Stand-By	3.5W	3.5W
Luminance of White		450 cd / m ²	700 cd / m ²
Contrast ratio (Dark Room)		4,500 : 1	3,000 : 1
Seam Gap (Multi Configuration)		7.3mm	
Active Display Area		1018.353(H) X 572.544(V) mm	
Aspect Ratio		16 : 9	
Number of pixels		1366 (H) X 768 (V)	
Pixel Pitch		0.7455 X 0.7455 mm	
Display Colors		16.7M	
Viewing Angle		H : 178°, V : 178°	
Response Time		8msec (G to G)	
Environmental condition	Temperature	5°C ~ 35°C	
	Humidity	35% ~ 75%	
Input Signal	PC / DVI Signal (Not support HDCP)	VGA, SVGA, XGA, SXGA, UXGA, WXGA, 480p,576p,720p(50/60),1080i(50/60),1080p(50/60)	
	Video Signal	NTSC, PAL, SECAM	
	Frequency	H : 31.5 ~ 75kHz, V : 50 , 60 Hz	
In/Output Terminal	Input	DVI-D x 1, PC x 1, Video x 1, RS-232C x 1, LAN x1, Service x 1	
	Output	DVI-D x 1, PC x 1, Video x 1, RS-232C x 1	
Lamp Life Tme		Min 50,000Hrs (Ta : 25±2°C)	

Dimension 1025.7mm(W) x 579.8mm(H) x 100.23mm(D)

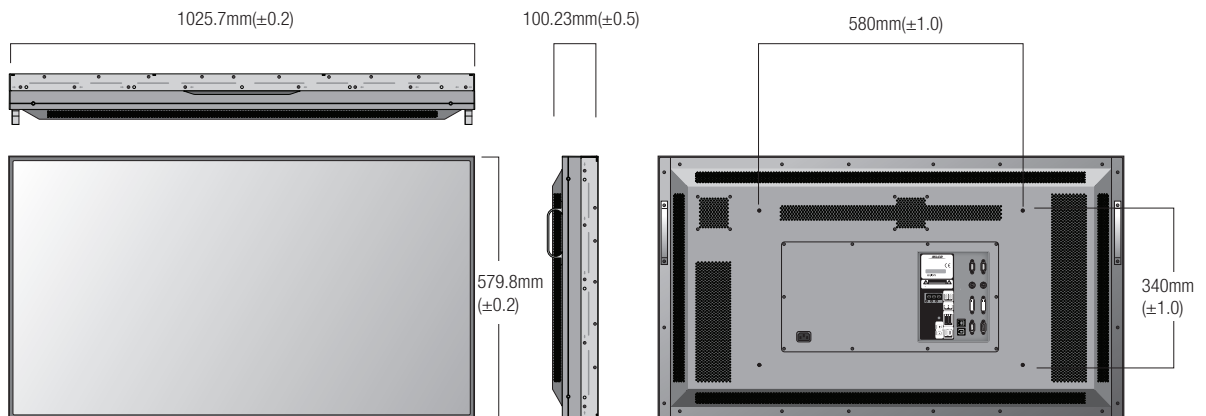

Weights	23Kg(±0.5Kg)	26Kg(±0.5Kg)
---------	--------------	--------------

※ Product design and specification can be changed for quality improvement without prior notice.